

HONG KONG OBSERVATORY

Technical Note No. 96

**CHARACTERISTICS OF SEA BREEZES
AT CHEK LAP KOK**

by

C.M. CHENG

COPYRIGHT RESERVED

Published May 1999

Prepared by

Hong Kong Observatory
134A Nathan Road
Kowloon
Hong Kong

This publication is prepared and disseminated in the interest of promoting information exchange. The findings, conclusions and views contained herein are those of the authors and not necessarily those of the Hong Kong Observatory or the Government of the Hong Kong Special Administrative Region.

The Government of the Hong Kong Special Administrative Region (including its servants and agents) makes no warranty, statement or representation, express or implied, with respect to the accuracy, completeness, or usefulness of the information contained herein, and in so far as permitted by law, shall not have any legal liability or responsibility (including liability for negligence) for any loss, damage, or injury (including death) which may result, whether directly or indirectly, from the supply or use of such information.

Mention of product of manufacturer does not necessarily constitute or imply endorsement or recommendation.

Permission to reproduce any part of this publication should be obtained through the Hong Kong Observatory.

551.553.11(512.317)

摘要

本篇報告刊出有關赤鱘角的海風研究，對機場上的風向、風速及氣溫的數據作出了分析。本文敘述了赤鱘角海風形成的因素，並刊出有關海風的開始時間、持續時間及強度的統計。

Abstract

This note presents the study on sea breezes at Chek Lap Kok. Data of winds and temperatures on the airport were analyzed. An account of the factors contributing to sea breezes at Chek Lap Kok is given. Statistics pertaining to onset, duration and strength of sea breezes is also presented.

CONTENTS

	List of Figures	ii
	List of Tables	iii
I	Introduction	1
II	Sea Breeze Circulation at Chek Lap Kok	1
III	Data Base	3
IV	Characteristics of Winds at Sea Breeze Hours	5
V	Statistics on Onset, Duration and Cessation of Sea Breezes	9
VI	Statistics on Cloud Cover, Temperature and Sunshine Duration	11
VII	Effect of Background Winds on Sea Breeze Onset Hour and Sea Breeze Duration	14
VIII	Cases of Sea Breezes	16
IX	Conclusion	18
	Acknowledgment	23
	References	23

LIST OF FIGURES :

- Figure 1. Simple model of sea breeze circulation. Arrows indicate the circulation of sea breeze. P0, P1 and P2 represent the planes of equal pressure.
- Figure 2. Map of Hong Kong showing the location of the runway anemometer sites (R1E, R1C and R1W) at Chek Lap Kok, the Meteorological Enclosure at Chek Lap Kok (HKA), the Hong Kong Observatory Headquarters (HKO), North Point (NP) and Waglan Island (WGL).
- Figure 3. Types of Sea Breezes at Chek Lap Kok.
- Figure 4. Windroses for Waglan Island. (Circles at 10% interval. Same below.)
- Figure 5. Windroses for R1E.
- Figure 6. Windroses for R1C.
- Figure 7. Windroses for R1W.
- Figure 8. Frequency distribution of Sea Breeze Onset Hour.
- Figure 9. Frequency distribution of Sea Breeze End Hour.
- Figure 10. Frequency distribution of Sea Breeze Duration.
- Figure 11. Frequency distribution of cloud cover at CLK at sea breeze hours.
- Figure 12. Frequency distribution of (Maximum temperature at Chek Lap Kok - Sea surface temperature at North Point).
- Figure 13. Frequency distribution of sunshine duration at Hong Kong Observatory.
- Figure 14. Plot of sea breeze onset hours against the wind speed at Waglan Island at the onset hour of sea breeze. The dash line is the line of least square fit to the data.
- Figure 15. Plot of sea breeze onset hours against the eastern component of winds at Waglan Island at the onset hour of sea breeze. The dash line is the line of least square fit to the data.
- Figure 16. Plot of sea breeze duration against the mean wind speed at Waglan Island during sea breeze hours. The dash line is the line of least square fit to the data.
- Figure 17. Synoptic weather chart at 8 a.m. on 15 October 1997.
- Figure 18. Synoptic weather chart at 8 a.m. on 7 October 1997.
- Figure 19. Synoptic weather chart at 8 a.m. on 28 July 1997.
- Figure 20. Wind flow over Hong Kong on 15 October 1997 at (a) 9 a.m., (b) 10 a.m., (c) 11 a.m., (d) 2 p.m..
- Figure 21. Wind flow over Hong Kong on 7 October 1997 at (a) 9 a.m., (b) noon, (c) 1 p.m., (d) 4 p.m..

Figure 22. Wind flow over Hong Kong on 28 July 1997 at (a) 6 a.m., (b) 9 a.m., (c) 2 p.m., (d) 3 p.m..

LIST OF TABLES :

Table1. Source of data.

Table2. Comparison of percentage of winds at R1E, R1C, R1W and WGL during sea breeze hours. The bracketed values are the corresponding percentages of winds during the whole study period.

Table3. Comparison of wind strength (in m/s) at R1E, R1C and R1W during sea breeze hours. The bracketed values are the equivalent strength in Beaufort scale.

I. Introduction

In a coastal region like Hong Kong, the occurrence of sea breezes results in abrupt wind shifts, which pose difficulties in wind forecasting. Accurate prognostication of sea breeze is valuable to forecasting of winds. This is particularly important at an aerodrome where landing direction of runway is determined by the wind flow over the aerodrome. The airport operations will benefit from the accurate anticipation of landing direction change.

The Hong Kong International Airport at Chek Lap Kok exhibits complicated sea breeze circulation due to the complex surrounding terrain. The aim of the present study is to find out the characteristic and statistics pertaining to the onset, duration and strength of sea breezes at the new airport.

II. Sea Breeze Circulation at Chek Lap Kok

The mechanism of sea breezes has been known for many years [Atkinson, 1981, Hsu 1988 and Simpson, 1994]. Sea breeze circulation is generally recognized as an air-sea-land interaction induced by differential heating on land and sea surface. [Figure 1](#) shows how sea breeze circulation is generated.

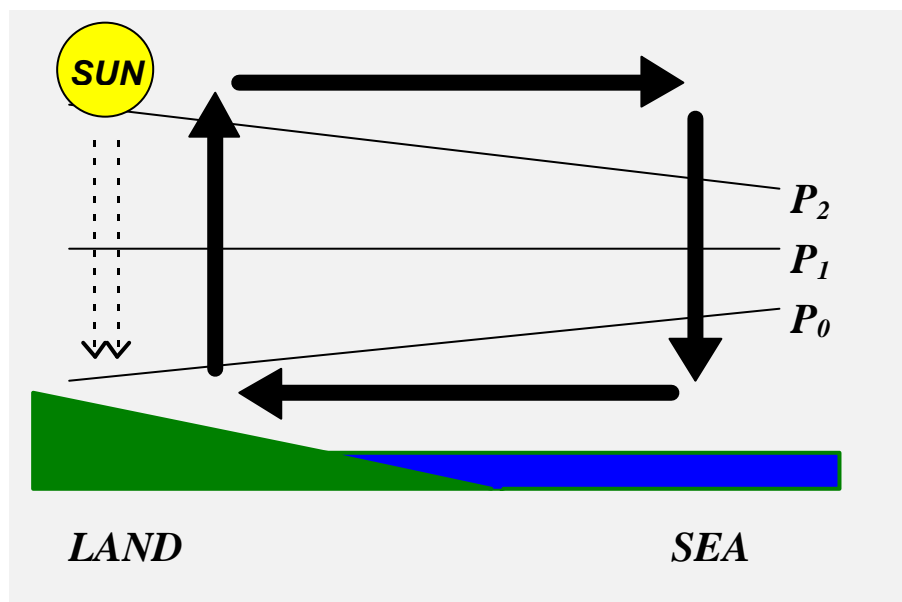

Figure 1 Simple model of sea breeze circulation. Arrows indicate the circulation of sea breeze. P_0 , P_1 and P_2 represent the planes of equal pressure.

During the day the land heats up more quickly than the neighbouring sea. As the air over the land warms up, it rises and creates low pressure near the land surface. The rising air accumulates aloft and produce higher pressure than the air at the same height over the sea. This pressure gradient induces offshore flow of air aloft. Surface high pressure develops over the sea in response to the accumulation of air at higher levels,

thereby creating a pressure gradient from the sea to the shore. The resulting flow from the sea to the land completes the sea breeze circulation.

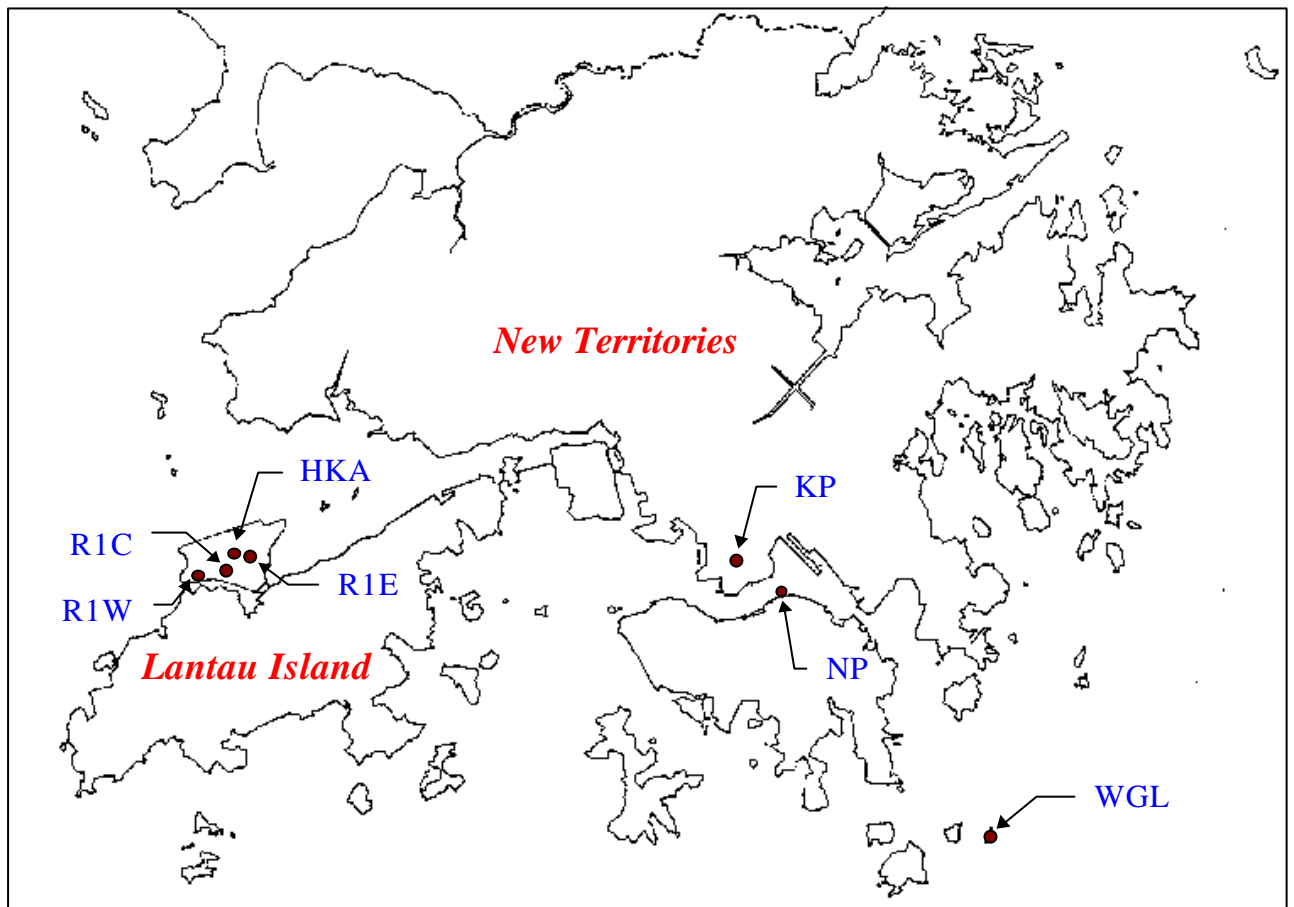

Figure 2 Map of Hong Kong showing the location of the runway anemometer sites (R1E, R1C and R1W) at Chek Lap Kok, the Meteorological Enclosure at Chek Lap Kok (HKA), King's Park (KP), North Point (NP) and Waglan Island (WGL).

Figure 2 shows the location of Chek Lap Kok. The new airport is situated on a flat piece of land to the immediate north of Lantau Island. To the northeast of Chek Lap Kok locates the main landmass in Hong Kong, namely, the New Territories. Three types of sea breezes can be identified at Chek Lap Kok. Firstly, since the new airport is surrounded by waters, sea breezes converge from all directions to the centre of the island when it is heated up. This results in opposite wind directions at the two ends of the runway (ref. type I sea breeze in Figure 3). Secondly, Lantau Island, being a larger landmass than Chek Lap Kok, induces sea breezes which blow across the new airport from the north to northwest (ref. type II sea breeze in Figure 3). Finally, the New Territories, when heated up by the sun, draw in air from all directions. The sea breezes so generated flow across Chek Lap Kok from the southwest (ref. type III sea breeze in

Figure 3). Since Chek Lap Kok and Lantau Island are smaller in size than the New Territories, the sea breezes induced by Chek Lap Kok and Lantau Island (Types I and II sea breezes) are somewhat weaker in strength and are usually suppressed by the sea breeze induced by the New Territories (type III sea breezes). Some typical examples of these three types of sea breezes are presented in Section III.

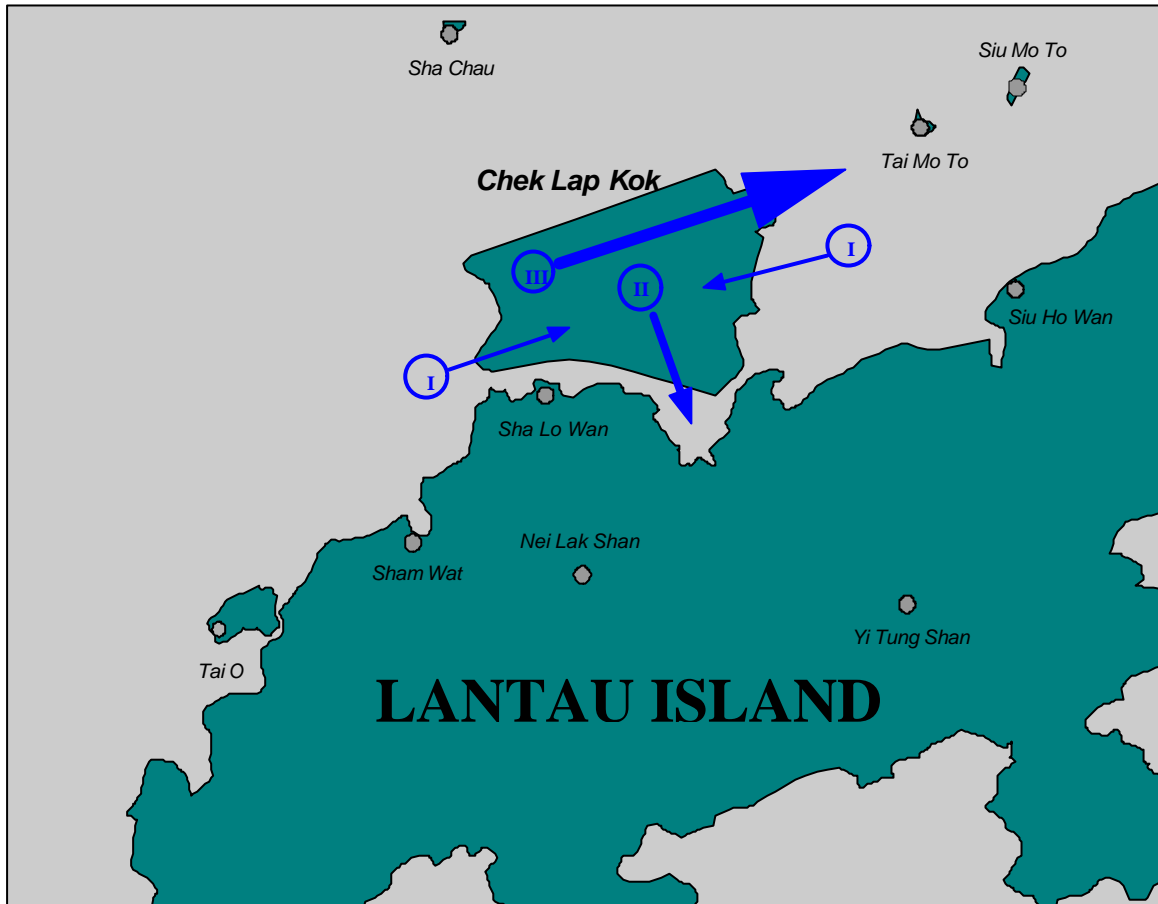

Figure 3 Types of Sea Breezes at Chek Lap Kok.

III. Data Base

Data from the three anemometers along the southern runway on Chek Lap Kok, namely, R1E, R1C and R1W will be analyzed (see Figure 2). Wind data at Waglan Island (WGL) are used as an indicator of background wind flow. Temperature and cloud cover recorded at the Meteorological Enclosure on Chek Lap Kok (HKA), the sunshine duration data at King's Park (KP) and the sea surface temperature at North Point (NP) are also employed in the analysis. The locations of these sites are shown in Figure 2. Table 1 lists out the characteristics of the data used in the present study.

Table 1 Source of data.

Station	Data type	Time period	Frequency of data
<i>RIE (southern runway east)</i>	10-minute mean wind direction and speed	June 1997 - October 1997	hourly
<i>RIC (southern runway centre)</i>	10-minute mean wind direction and speed		
<i>RIW (southern runway west)</i>	10-minute mean wind direction and speed		
<i>HKA (Meteorological enclosure at Chek Lap Kok)</i>	Air temperature, Cloud cover		
<i>WGL (Waglan)</i>	10-minute mean wind direction and speed		
<i>KP (King's Park)</i>	Sunshine duration		daily
<i>NP (North Point)</i>	Sea surface temperature		

In the present study, sea breezes at Chek Lap Kok are said to occur when the winds at any one of the three anemometer sites on the southern runway deviate abruptly from a steady background wind flow. This is manifested as a sudden wind shift at any one of the three anemometer sites caused by the development of any one of the three types of sea breezes at Chek Lap Kok. 'Sea breeze onset hour' is the hour of the day when sea breezes start to occur at Chek Lap Kok while 'Sea breeze end hour' is the hour of the day when sea breezes cease to occur. 'Sea breeze duration' is the time elapsed from the sea breeze onset hour to the sea breeze end hour. 'Sea breeze hours' refer to the time during which sea breezes occur at Chek Lap Kok while 'Sea breeze day' is the day on which sea breezes are observed at Chek Lap Kok.

IV. Characteristics of Winds at Sea Breeze Hours

(a) Background winds at Waglan Island

Figure 4(a) shows the windrose of Waglan Island for the period under study. During this period, 41% of the winds came from the east to northeast. There was also 23% of winds from the southwest. Figure 4(b) is the windrose of Waglan Island during sea breeze hours. This is distinctly different from the wind pattern in Figure 4(a). First of all, about 75% of winds at Waglan Island came from the east to northeast during sea breeze hours. This is nearly twice the percentage in Figure 4(a). Secondly, nearly all the winds during sea breeze hours are light to moderate in strength. This suggests that the favourable background wind conditions for sea breeze to occur at Chek Lap Kok is light winds or moderate east to northeasterlies.

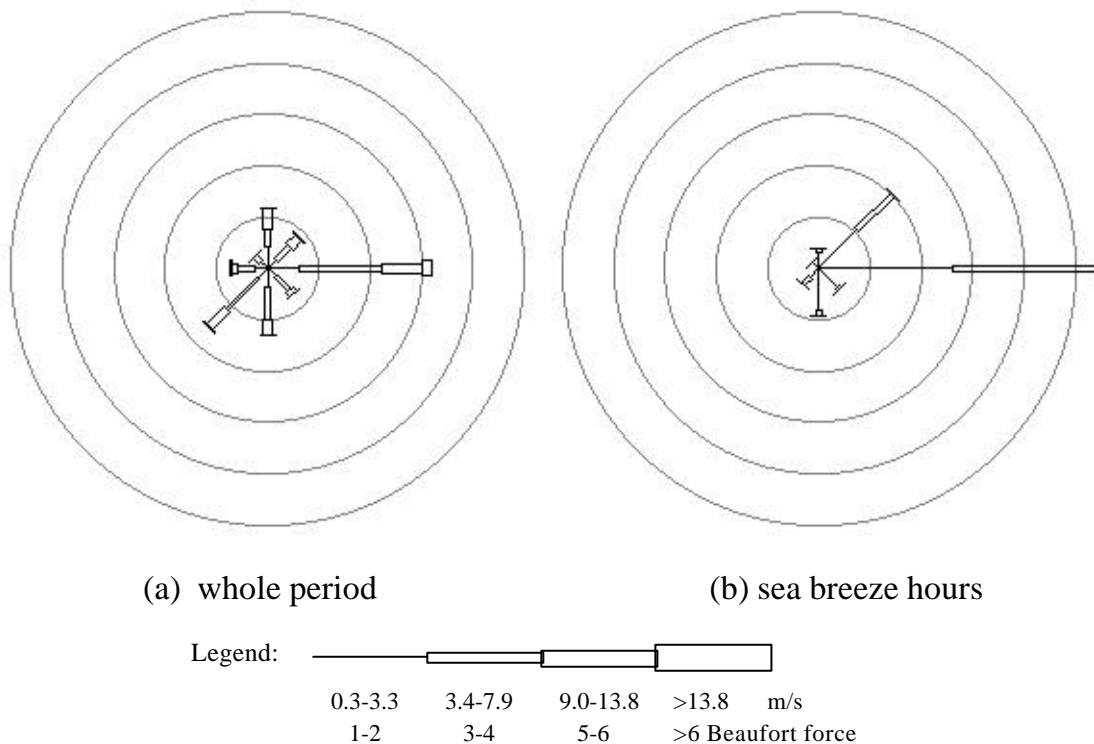

Figure 4 Windroses for Waglan Island. (Circles at 10% interval. Same below.)

(b) Winds at R1E

Figure 5 depicts the windrose of R1E for the period under study (Figure 5(a)) and the corresponding windrose during sea breeze hours (Figure 5(b)). It can be seen that the percentage of winds from the east to northeast at R1E during the study period is 39% which is about the same as the figure for Waglan Island. In Figure 5(b), however, the percentage of east to northeasterly winds during sea breeze hours is reduced to only 27%. About 33% of winds during sea breeze hours came from the west and around 31% of winds were north to northwesterlies. The high percentage of westerly winds during

sea breeze hours can be attributed to the occurrence of type III sea breeze while the high percentage of northwesterly winds are suggestive of type II sea breeze.

(c) *Winds at R1C*

The windrose of R1C for the study period and the respective windrose during sea breeze hours can be found in Figure 6(a) and 6(b). As compared to the windrose for R1E for the study period, there is more or less the same percentage of east to northeasterly winds at R1C. During sea breeze hours, there is significantly less winds from the east to northeast, the percentage of which is only 7%. On the contrary, 57% of winds came from the west to southwest which is evident of type III sea breeze. Meanwhile, 23% of winds were from the north to northwest, which is an indication of type II sea breeze.

(d) *Winds at R1W*

Figure 7(a) and 7(b) show the windroses of R1W for the study period and for sea breeze hours respectively. The percentage of east to northeasterly winds at R1W during the study period is more or less the same as those at the other two runway sites, i.e. R1E and R1C. During sea breeze hours, the predominant winds at R1W were west to southwesterlies. The percentage amounts to 69%. This high percentage can be attributed to the combined effect of type I and type III sea breezes. Type II sea breeze also contribute to 25% of north to northwesterly winds.

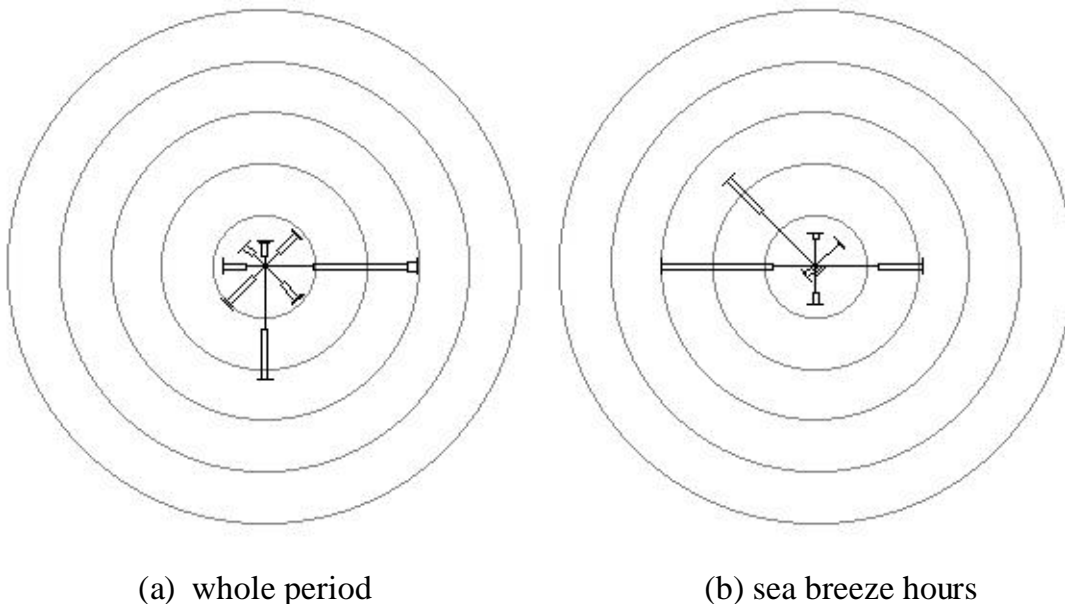
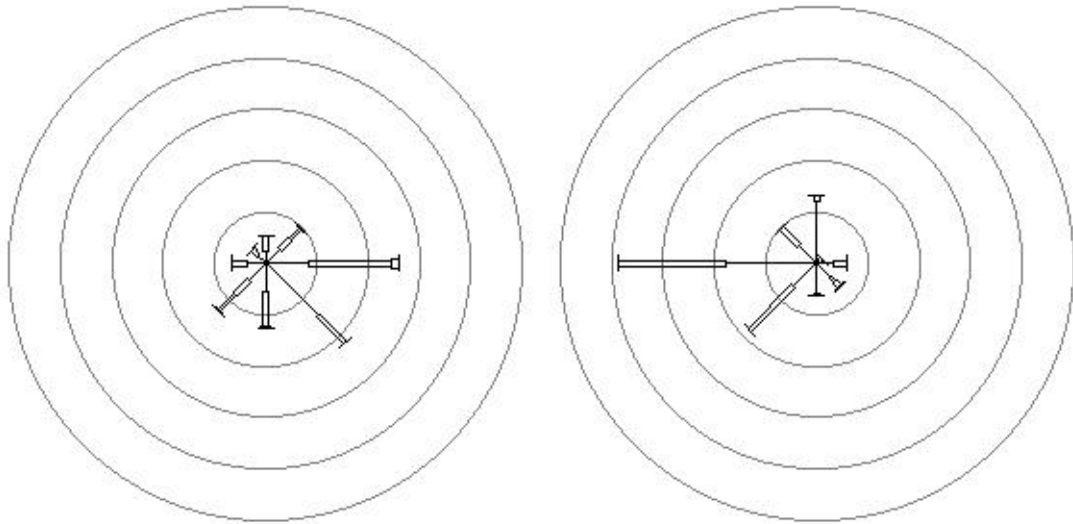

Figure 5 Windroses for R1E.



(a) whole period

(b) sea breeze hours

Figure 6 Windroses for R1C.

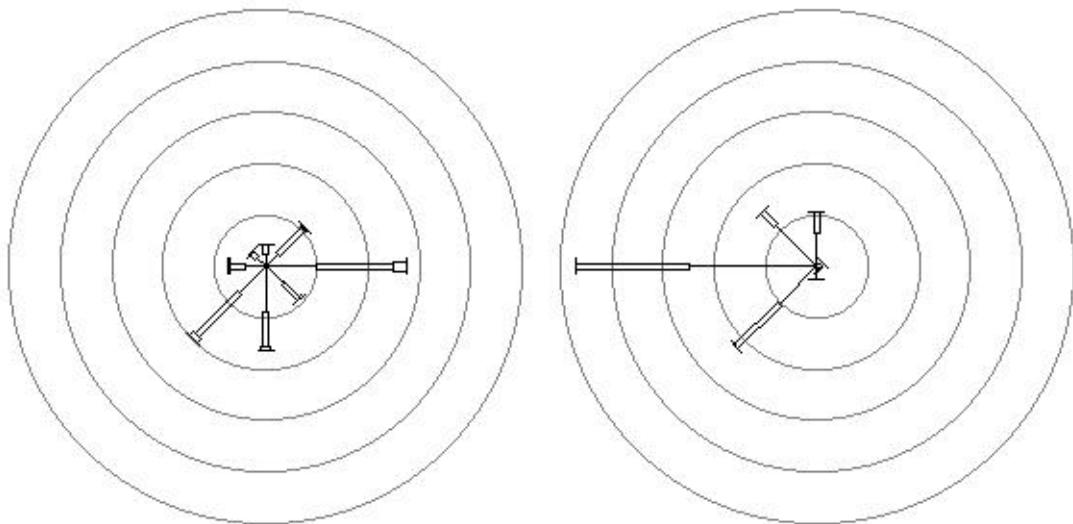

(a) whole period

(b) sea breeze hours

Figure 7 Windroses for R1W.

(e) *Comparison of Winds at R1E, R1C and R1W*

Table 2 shows the percentage of winds at the three runway sites and at Waglan Island during sea breeze hours. While east to northeasterlies predominate at Waglan Island, there is more west to southwesterly winds than north to northeasterlies at the three runway sites. This is particularly so at R1W where very little winds came from the east to northeast. There is a trend of higher percentage of east to northeasterly winds and lower percentage of west to southwesterly winds at the east than at the west. This is due to the fact that when type I sea breeze occurs, winds converge from both sides of the

runway, leading to east to northeasterlies at R1E but west to southwesterlies at R1W. Higher percentage of west to southwesterly winds and lower percentage of east to northeasterly winds at R1W than at R1E is therefore a natural consequence of type I sea breeze. The general high percentage of west to southwesterly winds at the three runway sites during sea breeze is a manifestation of type III sea breeze.

During sea breeze hours, the percentages of north to northwesterly winds at the three runway sites range from 23 to 31%, which are two to three times higher than those percentages for the whole study period. This can be attributed to the occurrence of type II sea breeze.

The mean wind strength of sea breezes at the three runway sites is tabulated in [Table 3](#). Generally speaking, the strength at sea breezes at the three runway sites are light to moderate. There is a tendency of higher strength of winds from the west to southwest than from the east to northeast or from the north to northwest. As discussed before, south to southwesterlies are associated with type III sea breezes. The results in [Table 3](#) indicate higher strength of type III sea breezes than the other two types.

Table 2 Comparison of percentage of winds at R1E, R1C, R1W and WGL during sea breeze hours. The bracketed values are the corresponding percentages of winds during the whole period.

Wind direction	Site			
	<i>R1W</i>	<i>R1C</i>	<i>R1E</i>	<i>WGL</i>
<i>East to northeast</i>	1% (38%)	7% (36%)	27% (39%)	75% (41%)
<i>North to northwest</i>	25% (8%)	23% (9%)	31% (10%)	6% (15%)
<i>West to southwest</i>	69% (27%)	57% (20%)	33% (19%)	4% (23%)

Table 3 Comparison of wind strength (in m/s) at R1E, R1C and R1W during sea breeze hours. The bracketed values are the equivalent strength in Beaufort scale.

Wind direction	Site		
	<i>R1W</i>	<i>R1C</i>	<i>R1E</i>
<i>East to northeast</i>	3.5 (Force 1)	3.0 (Force 2)	2.8 (Force 2)
<i>North to northwest</i>	2.7 (Force 2)	2.5 (Force 2)	2.8 (Force 2)
<i>West to southwest</i>	3.3 (Force 2)	3.4 (Force 3)	3.5 (Force 3)

V. Statistics on Onset, Duration and Cessation of Sea Breezes

(a) Frequency distribution of sea breeze onset hour

Figure 8 shows the frequency distribution of sea breeze onset hours. The most favourable time when sea breezes start is 10 a.m. which is roughly 3 to 4 hours after sunrise. Some events start as late as 1 p.m. and 2 p.m. but most of the sea breeze events start before noontime.

(b) Frequency distribution of sea breeze end hour

Figure 9 illustrates the frequency distribution of sea breeze end hour. A high percentage of sea breeze events end at 5 p.m. which is just about 1 to 2 hours before sunset. Around 70% of the sea breeze events end between 3 to 5 p.m..

(c) Frequency distribution of duration of sea breeze events

The frequency distribution of sea breeze duration is shown in Figure 10. A large majority of sea breeze events persist for more than 4 hours. More than 50% of the sea breeze events last for seven hours or longer.

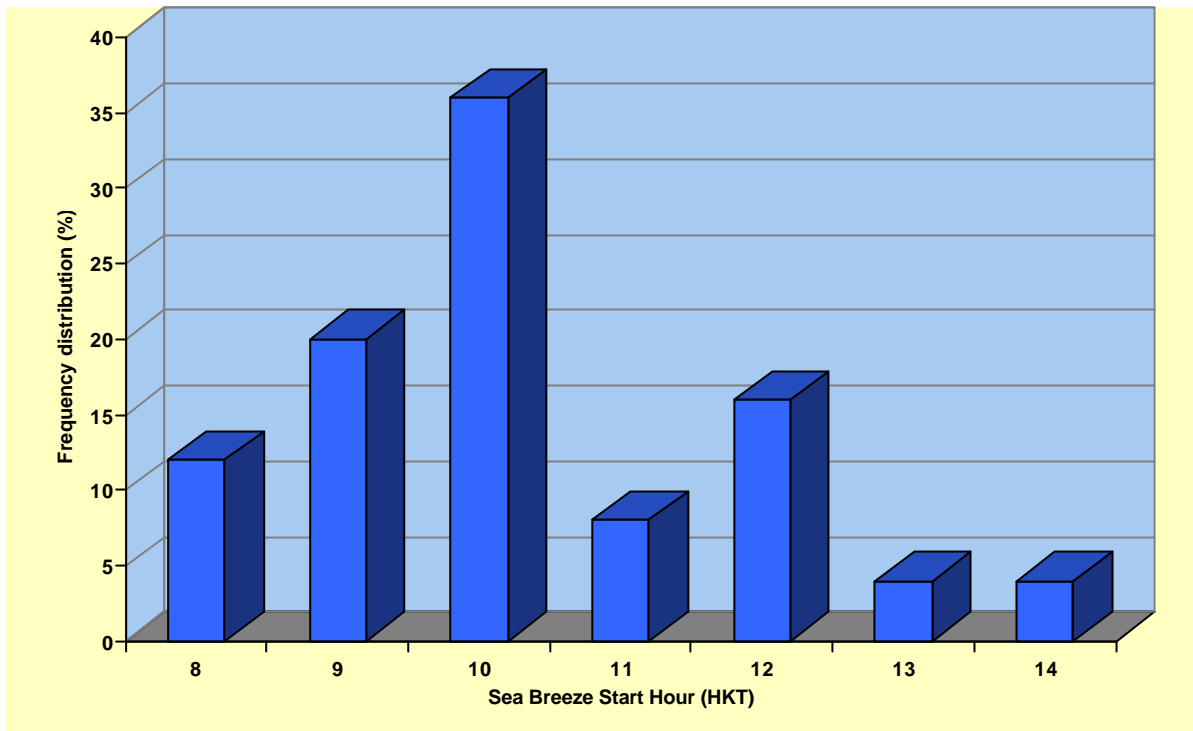

Figure 8 Frequency distribution of Sea Breeze Onset Hour.

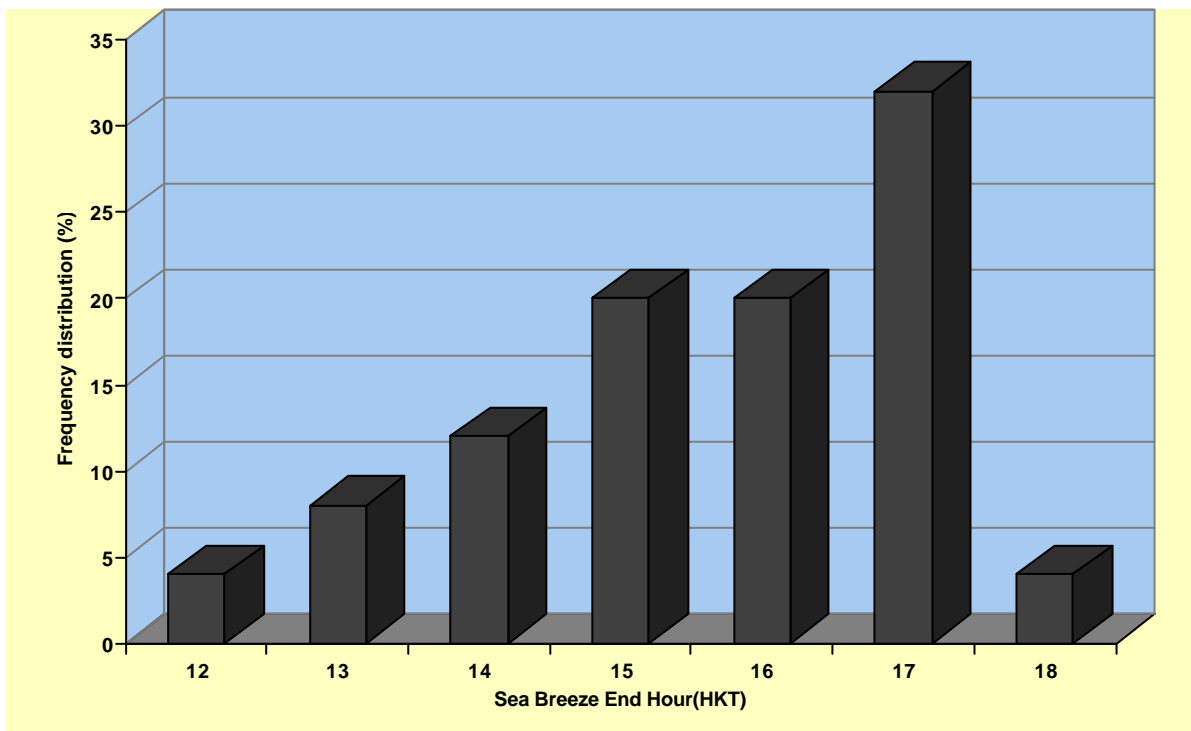

Figure 9 Frequency distribution of Sea Breeze End Hour.

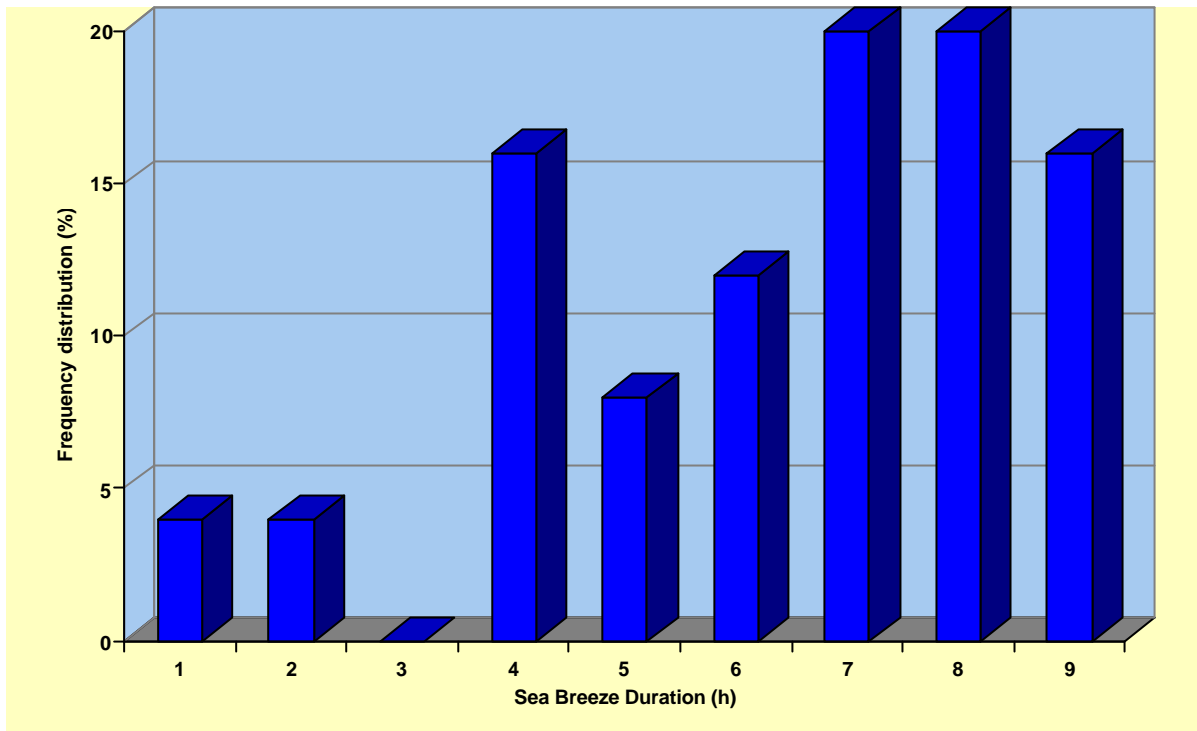

Figure 10 Frequency distribution of Sea Breeze Duration.

VI. Statistics on Cloud Cover, Temperature and Sunshine Duration

(a) *Frequency distribution of cloud cover at CLK*

Since sea breeze is driven by insolation, it is natural to think that there is not much cloud cover during sea breeze hours. From Figure 11 which shows the frequency distribution of cloud cover at CLK during sea breeze hours, it can be seen that cloud cover is 7 oktas for nearly half of the total number of sea breeze hours, though there is no case with full cloud cover. The high percentage of occurrence of 7 oktas of cloud cover is due to the fact that there is more clouds at the onset and cessation of sea breeze events. During the other hours when sea breezes occur, clouds generally decrease in amount which helps to let in more sunshine.

(b) Frequency distribution of temperatures at Chek Lap Kok

Since temperature difference between the land and the sea is crucial to sea breeze formation, it will be interesting to look at the frequency distribution of difference between maximum temperature at Chek Lap Kok and sea surface temperature at North Point, which is shown in Figure 12. Here the maximum temperature at Chek Lap Kok is the maximum hourly temperature at Chek Lap Kok. The sea surface temperature at North Point is the temperature recorded in the morning at North Point.

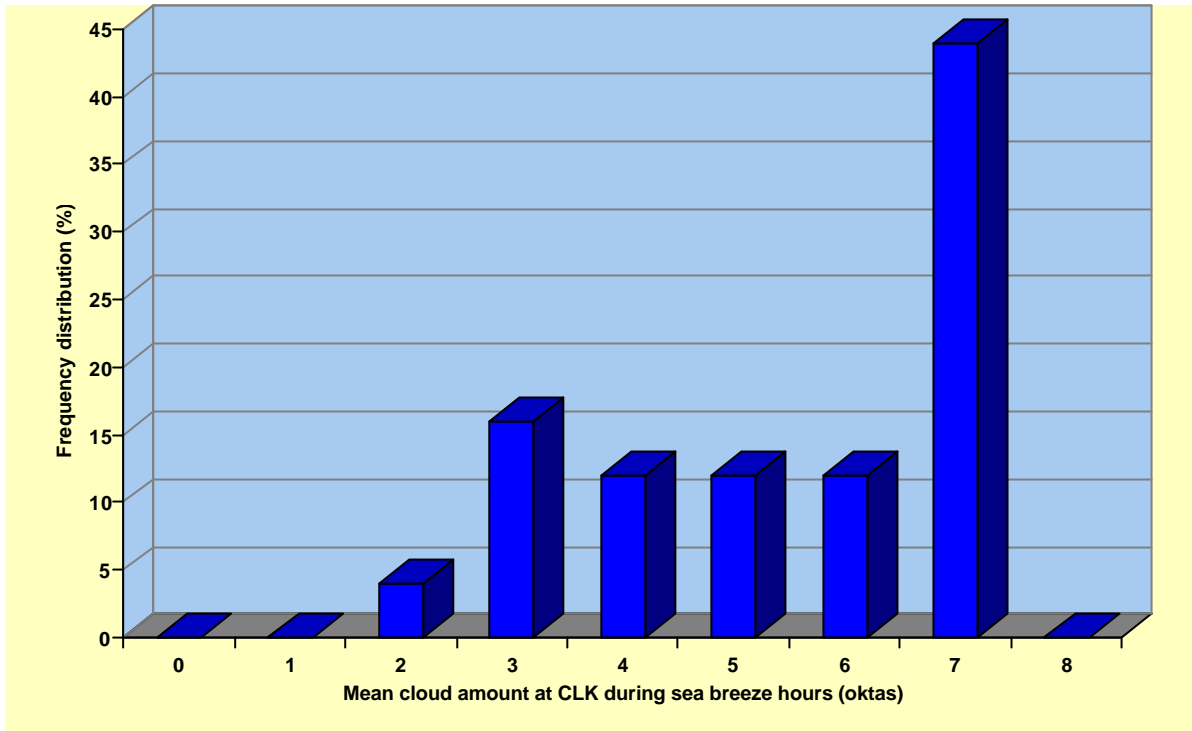

Figure 11 Frequency distribution of cloud cover at CLK at sea breeze hours.

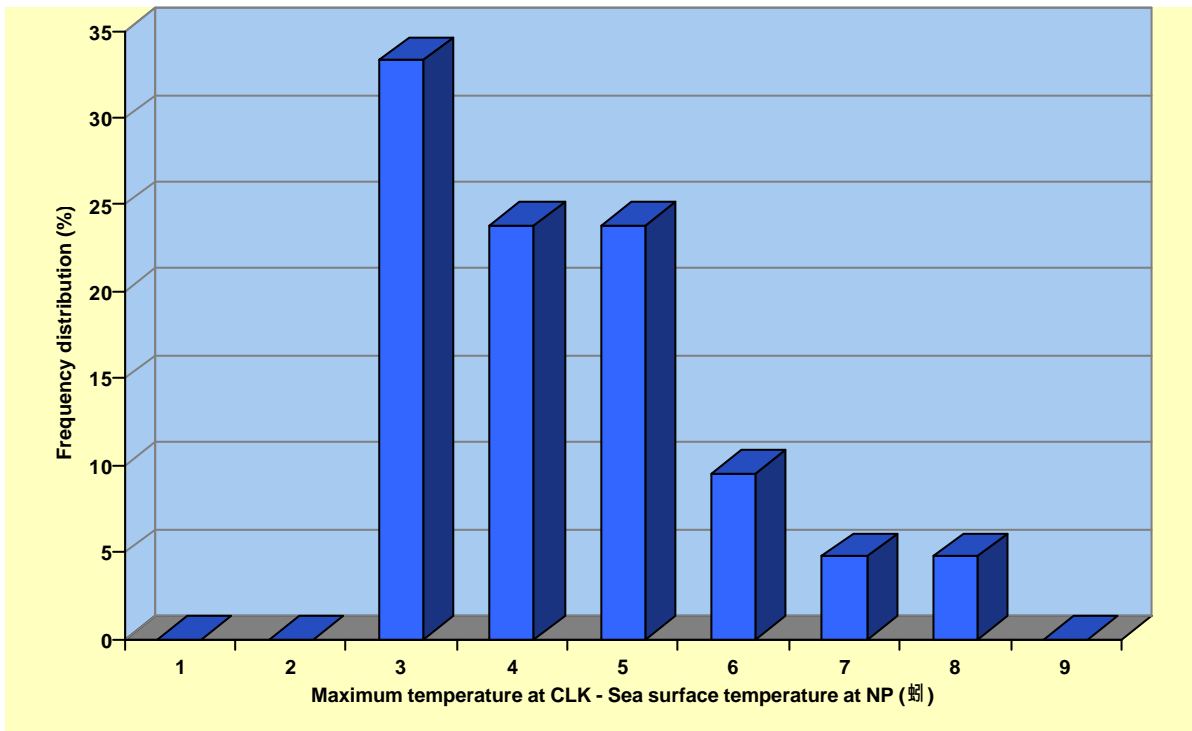

Figure 12 Frequency distribution of (Maximum temperature at Chek Lap Kok - Sea surface temperature at North Point).

The difference between maximum temperature at Chek Lap Kok and sea surface temperature at North Point ranges from 3 to 8 degrees. None of the sea breeze events occurred with the temperature difference below 3 degrees. This is reasonable because sea breeze can not develop when the temperature over land is not significantly higher than the sea surface temperature. The maximum temperature difference is 8 degrees. No higher temperature difference is recorded because sea breezes bring in relatively cooler air from the sea to regulate the temperature over land and prevent it from rising too high.

(c) Frequency distribution of sunshine duration

Sunshine duration affects how fast the land heats up. [Figure 13](#) illustrates the frequency distribution of sunshine duration recorded at King's Park (KP). A large majority of sea breeze events occurred when sunshine duration at the KP exceeded 5 hours. There are also cases where sunshine extended up to 12 hours. Although abundant sunshine favours sea breeze development, there was occasion with only three hours of sunshine. This was an event in which an easterly surge arrived to end the sea breeze event.

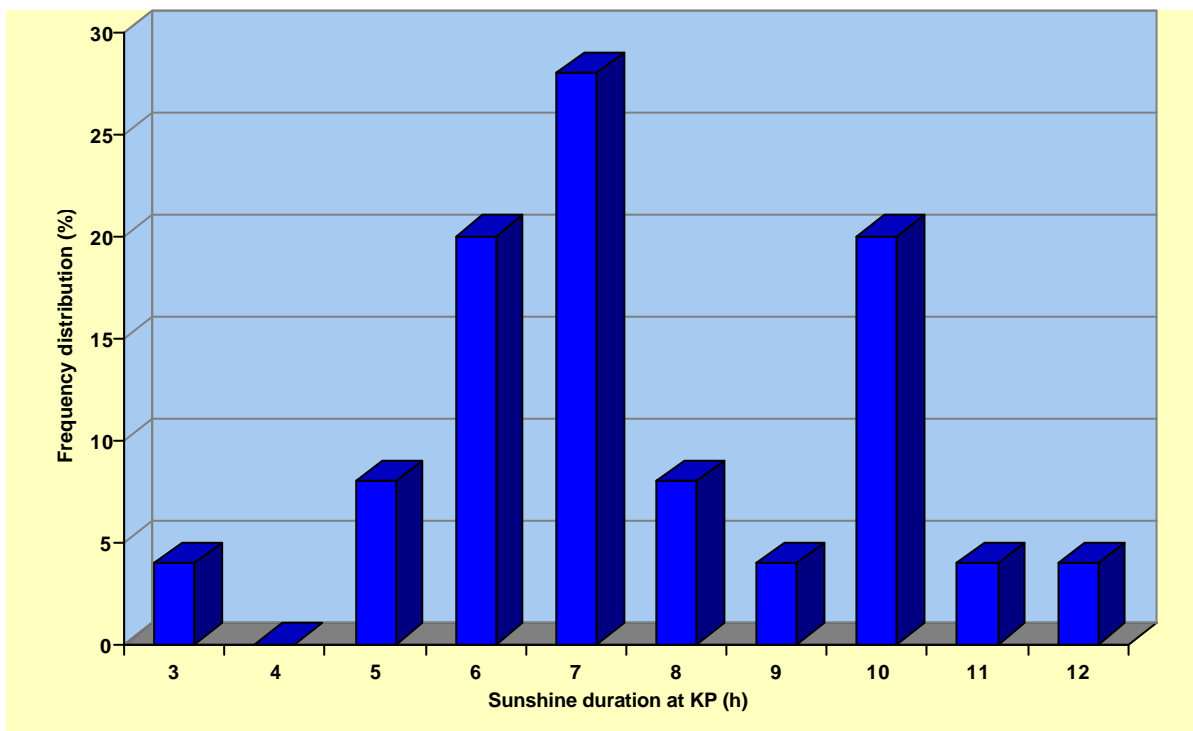

Figure 13 Frequency distribution of sunshine duration at King's Park.

VII. Effect of Background Winds on Sea Breeze Onset Hour and Sea Breeze Duration

(a) Effect of Background Wind Strength on Sea Breeze Onset Hour

To investigate the effect of background wind strength on the onset of sea breezes, the sea breeze onset hours are plotted against the wind speed at Waglan Island at the start time of sea breeze in Figure 14. The dash line in the figure shows the least square fit to the data and indicates a general rising trend of sea breeze onset hours with respect to increasing wind strength at Waglan Island. It is noted that when wind strength at Waglan Island is weak, namely, less than 2 m/s, sea breezes start no later than 10 a.m.. This indicates that sea breezes develop very quickly within a few hours from sunrise under low wind conditions. If sea breeze onset hours are plotted against the eastern component of winds at Waglan Island at the time of sea breeze starts in Figure 15, the rising trend of sea breeze onset hours with respect of increasing eastern component of winds at Waglan Island is more prominent. Like the case in Figure 14, sea breeze starts no later than 10 a.m. when the magnitude of the eastern component of winds at Waglan Island is less than 2 m/s. In addition, when the magnitude of the eastern component of winds at Waglan Island is more than 5 m/s, sea breeze starts later than 11 a.m.. This is a reasonable result in that stronger winds generally prevent land from heating up too fast, thereby reducing the temperature gradient across land-sea boundary and it will therefore take longer time for sea breezes to develop.

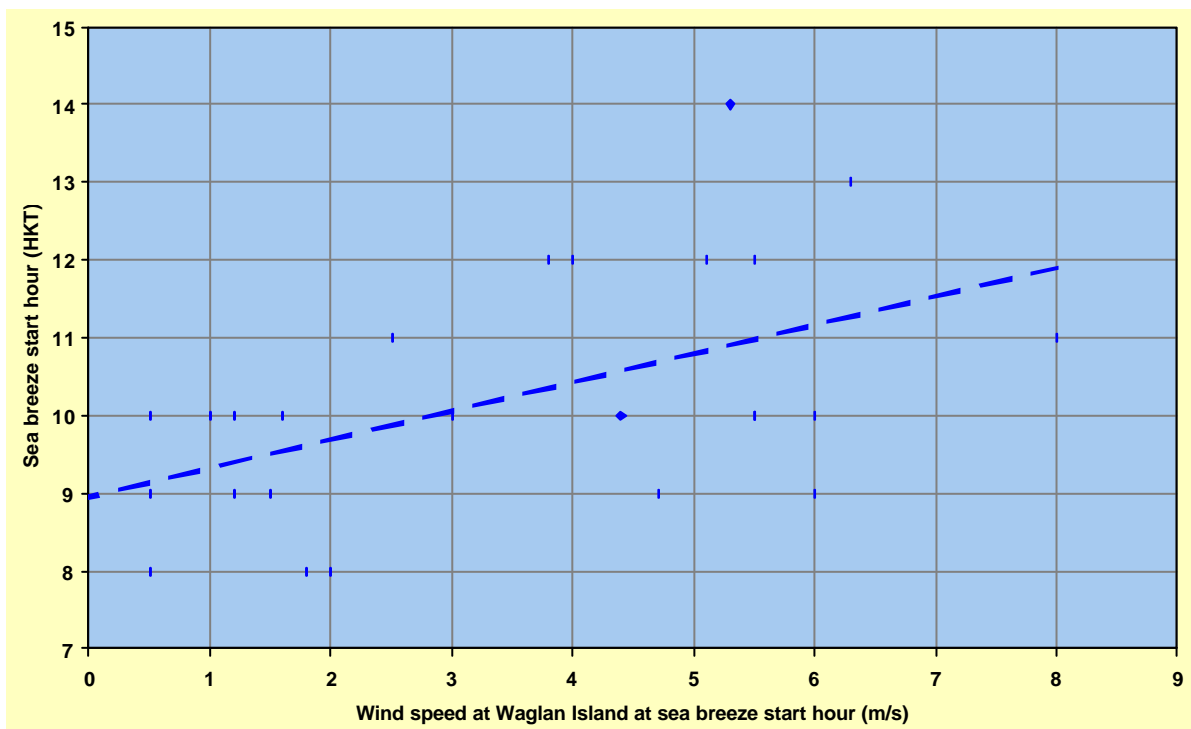

Figure 14 Plot of sea breeze onset hours against the wind speed at Waglan Island at the onset hour of sea breeze. The dash line is the line of least square fit to the data.

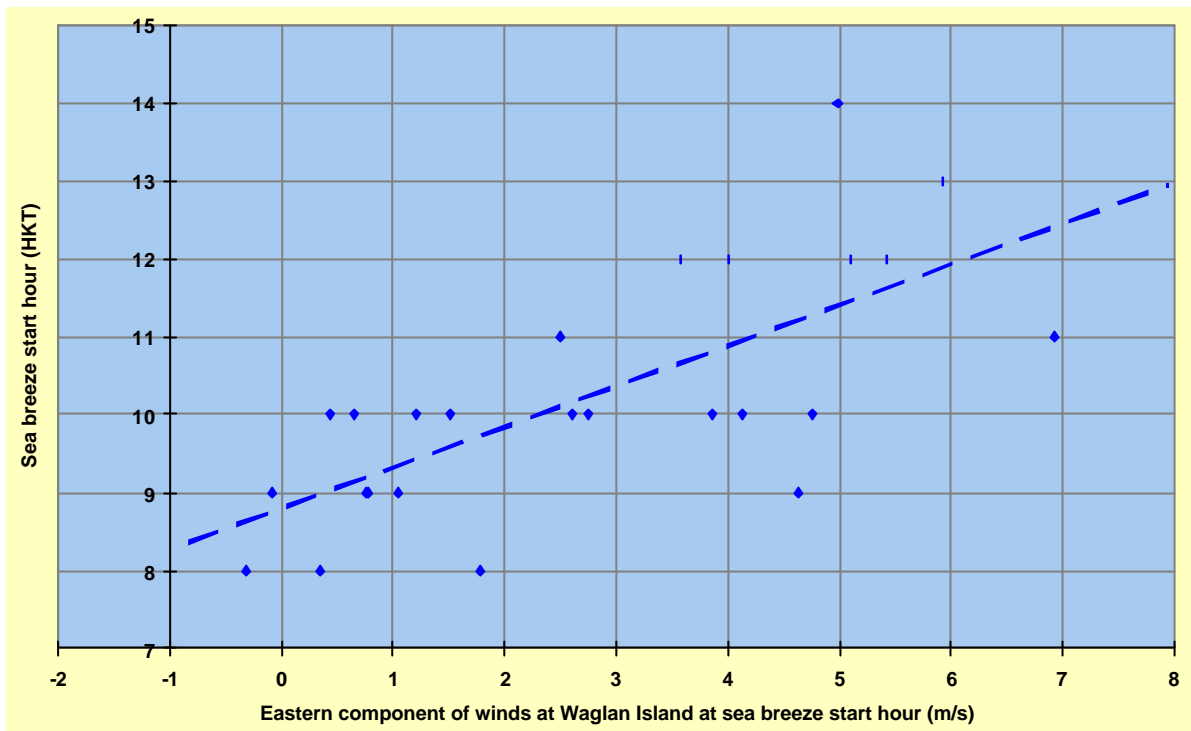

Figure 15 Plot of sea breeze onset hours against the eastern component of winds at Waglan Island at the onset hour of sea breeze. The dash line is the line of least square fit to the data.

(b) Effect of Background Wind Strength on Sea Breeze Duration

Figure 16 depicts the plot of sea breeze duration against the mean wind speed at Waglan Island during sea breeze hours. When the mean wind at Waglan Island is less than 5 m/s, the sea breeze events last for more than 4 hours. While the mean wind at Waglan Island is more than 5 m/s, the spread of sea breeze duration is large, ranging from 1 hour to 8 hours. The dash line in the figure is the least square fit to the data, which indicates a general trend of lower sea breeze duration for larger mean wind at Waglan Island during sea breeze hour. The least square fit is however not statistically significant, which means sea breeze duration does not correlate significantly with the mean wind at Waglan Island during sea breeze hours.

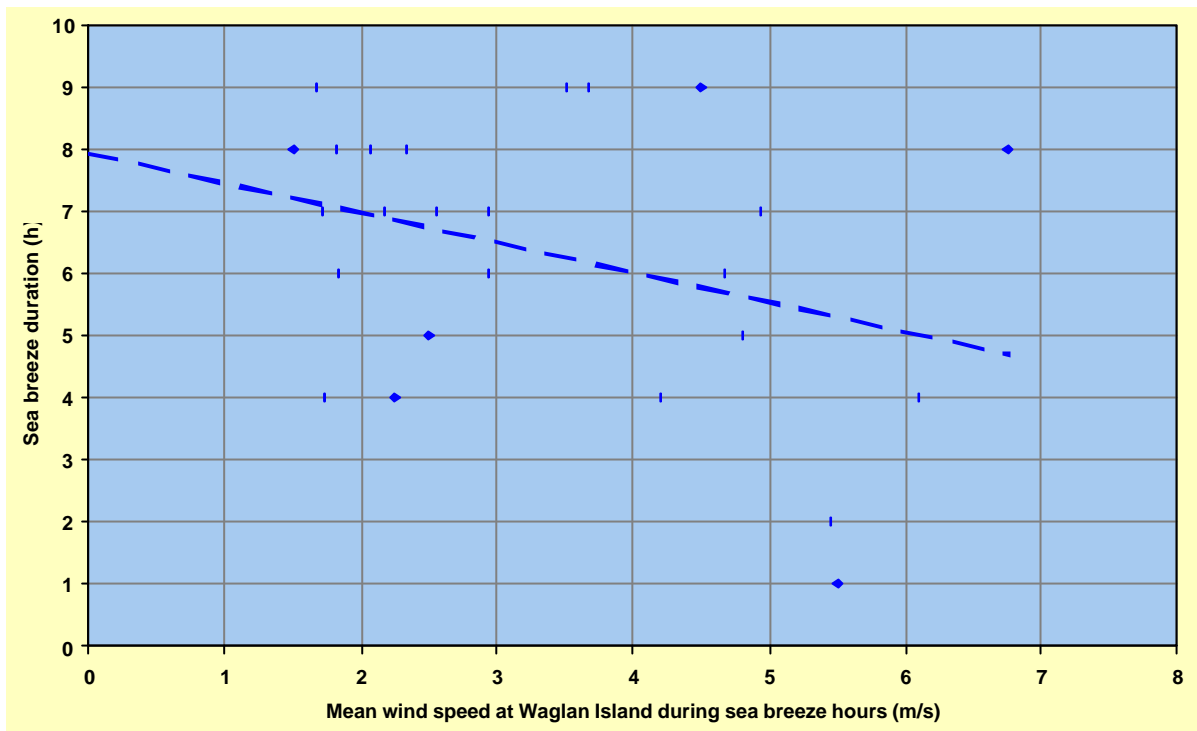

Figure 16 Plot of sea breeze duration against the mean wind speed at Waglan Island during sea breeze hours. The dash line is the line of least square fit to the data.

VIII. Cases of Sea Breezes

To illustrate how sea breeze develops, the meteorological conditions of a few cases of sea breeze are analyzed below:

(a) *Weak wind condition on 15 October 1997:*

This is a case with weak environmental wind flow. Synoptically, an area of high pressure resided over the central part of China while the pressure gradient over southern China was very weak (Figure 17). On average, there was only 36% of cloud cover throughout the day and 9.9 hours of sunshine were recorded.

Before on-set of sea breeze at Chek Lap Kok, winds were light all over the territory at 9 a.m. (Figure 20 a). At this time, light easterly winds prevailed over the new airport. Light southeasterly winds were recorded at the two island stations to the south of Lantau Island, which was indicative of sea breeze blowing into the Lantau Island from the southeast. One hour later at 10 a.m. (Figure 20 b), winds at R1C turned north while winds at R1W changed to the west. This is typical of type I sea breeze that develops locally on Chek Lap Kok. The way winds at R1C shifted from the east to the north can be attributed to the development of type II sea breeze. Note that the winds at the three runway sites were still light in strength while winds at Cheung Chau picked up to about 10 knots indicating strengthening of sea breeze onto Lantau Island from the southeast. At 11 a.m. (Figure 20 c), winds were light to moderate from the east over the harbour.

The winds at the runway sites turned to light west to southwesterlies, suggesting development of type III sea breeze. West to southwesterly wind flow persisted on Chek Lap Kok until 2 p.m. when winds on the runway turned back to the east (Figure 20 d).

(b) *Moderate easterly winds on 7 October 1997:*

On 7 October 1997, a ridge of high pressure along the southeast coast of China brought a moderate easterly flow to the coastal region of southern China (Figure 18). There was 6.8 hours of bright sunshine at the KP and the mean cloud cover at Chek Lap Kok was only 55% on that day.

At 9 a.m. (Figure 21 a), winds were generally moderate from the east over Hong Kong. About 15 knots of easterly winds were recorded at Waglan Island. On Chek Lap Kok, winds were weaker at about 5 knots. Under this moderate background wind flow, sea breeze did not develop until noon (Figure 21 b) when winds at R1W shifted to the west. At the same time, winds at R1C turned to the southwest. This indicated that type I sea breeze formed on the new airport. At 1 p.m. (Figure 21 c), type III sea breeze developed and winds became west to southwesterlies at Chek Lap Kok. Sea breeze persisted until 4 p.m. (Figure 21 d) when south to southeasterly winds dominated over the southern part of Hong Kong and winds at the three runway sites turned to the southeast as well.

(c) *High temperature on 28 July 1997:*

A ridge of high pressure extended from the Pacific Ocean to the southeastern China on 28 July 1997 (Figure 19). It was very hot on the day. The maximum temperature at the HKO was 33.0° C while that at Chek Lap Kok was 34.2° C. There was little cloud cover at Chek Lap Kok. The mean cloud amount is only 27%. A total of 9.9 hours of sunshine were recorded at the KP.

At dawn (Figure 22 a), winds were light throughout the territory. Temperatures at Chek Lap Kok and at the HKO was both 27° C. By 9 a.m. (Figure 22 b), temperature at Chek Lap Kok already rose to 30° C. Winds on the three runway sites shifted to the north to northwest which was indicative of type II sea breeze. In the following few hours, winds at Chek Lap Kok drifted to the west and strengthened a little (Figure 22 c). By that time, temperature at Chek Lap Kok rose further to 32° C and the winds were moderate at about 10 knots on the three runway sites. At 3 p.m., temperatures at Chek Lap Kok soared further to 34° C. Type I sea breeze developed and winds at R1E changed to the east. Despite the weak background wind flow (about 5 knots at Waglan Island), the high temperature at Chek Lap Kok induced sea breeze of about 10 knots in strength. Under the hot conditions on the new airport, sea breeze of considerable strength developed to replace the hot rising air above Chek Lap Kok. Sea breeze ceased at 4 p.m. when temperature at Chek Lap Kok fell to about 32° C.

IX. Conclusion

Wind data from the three runway sites at Chek Lap Kok and the winds at Waglan Island were studied. Results indicate that the favourable background wind conditions for sea breezes to develop at Chek Lap Kok is light winds or moderate east to northeasterly winds. Three types of sea breeze circulation can be identified:-

- (i) Type I :- local sea breeze circulation at Chek Lap Kok resulting from winds converging from all directions of the new airport;
- (ii) Type II :- winds converging to Lantau Island resulting in north to northwesterly winds on the runway sites; and
- (iii) Type III :- larger scale circulation with west to southwesterly winds flowing from Chek Lap Kok to the New Territories.

From the case study in the previous section, type III sea breeze is found to sustain a longer duration while type I and type II sea breeze occur for a shorter time period. It is observed that type I and type II sea breeze usually developed in the morning but eventually gave way to type III sea breeze which dominated over Chek Lap Kok.

Light winds favour earlier formation of sea breezes at or before 10 a.m.. At higher background winds of more than 5 m/s, sea breezes tend to form at later hours, namely, at or beyond 11 a.m.. Background wind speed did not have a strong bearing on the sea breeze duration but there is a tendency of shorter sea breeze duration at higher background winds.

Temperatures at Chek Lap Kok played a role in sea breeze formation. None of sea breeze cases occurred when the maximum temperature at Chek Lap Kok is lower than 2 degrees above the sea surface temperature at North Point.

In the current study, a few months of data at Chek Lap Kok were utilized. It is intended that data are collected over a longer time period for an analysis so that seasonal behaviour in sea breeze occurrence can also be studied.

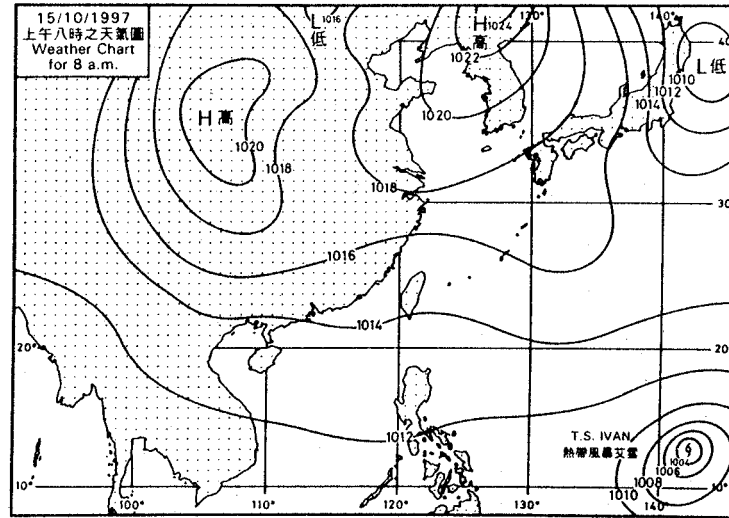

Figure 17 Synoptic weather chart at 8 a.m. on 15 October 1997

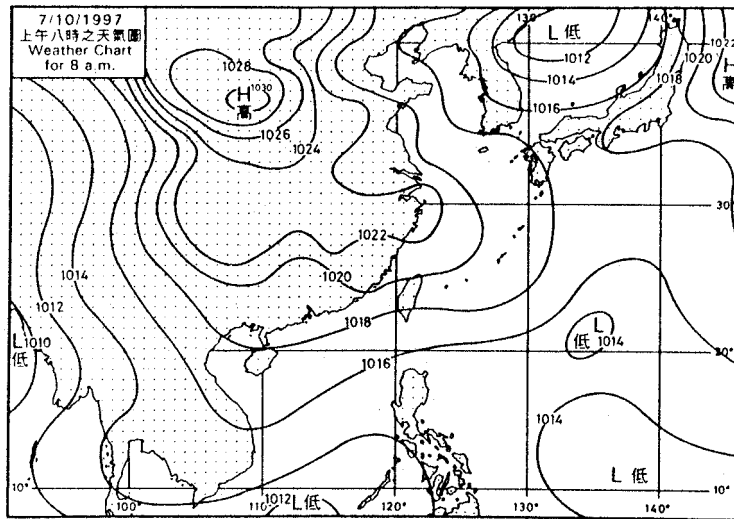

Figure 18 Synoptic weather chart at 8 a.m. on 7 October 1997

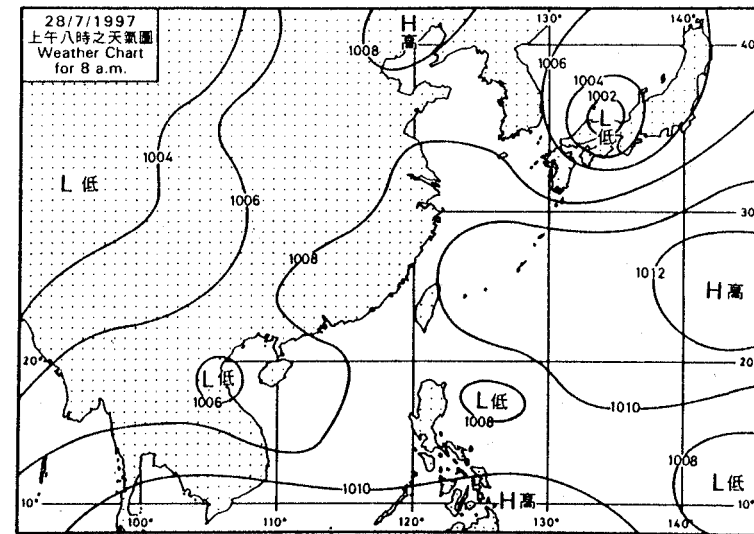
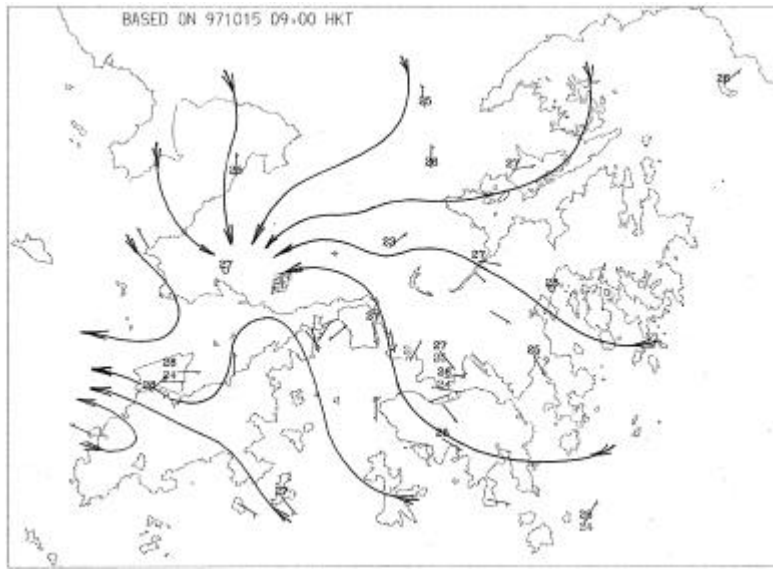
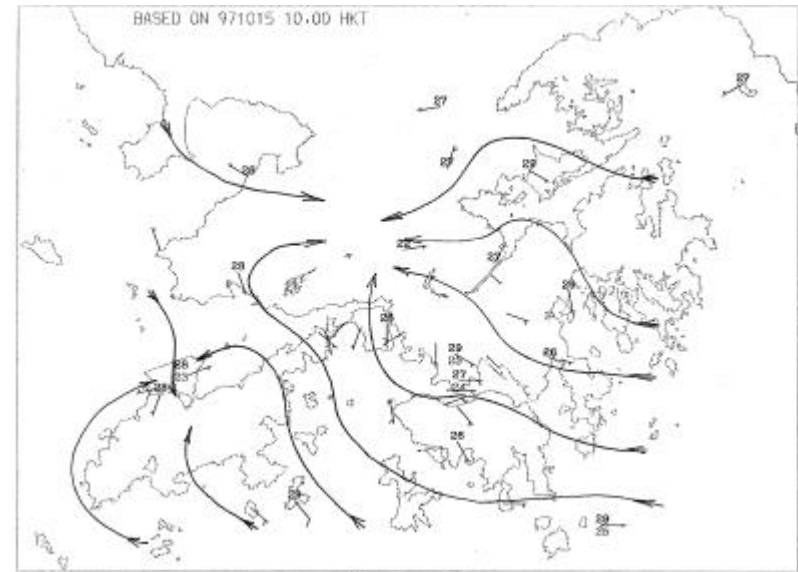

Figure 19 Synoptic weather chart at 8 a.m. on 28 July 1997



(a)



(b)

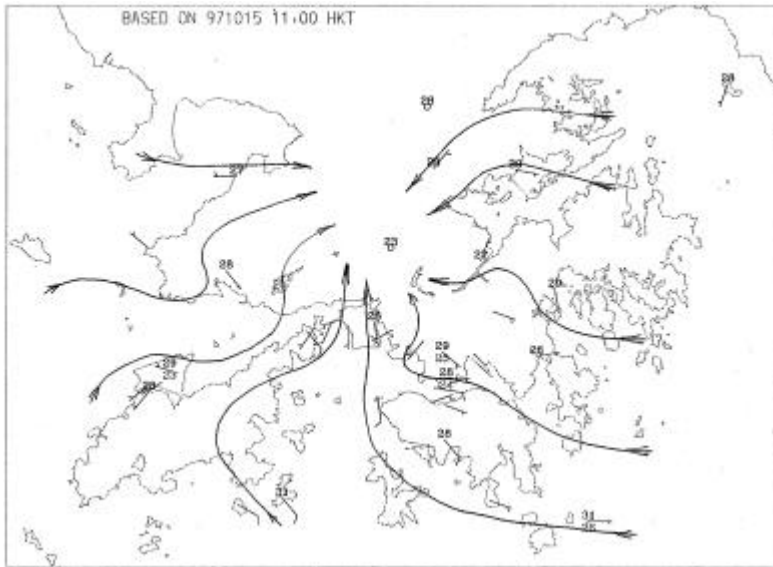

(c)

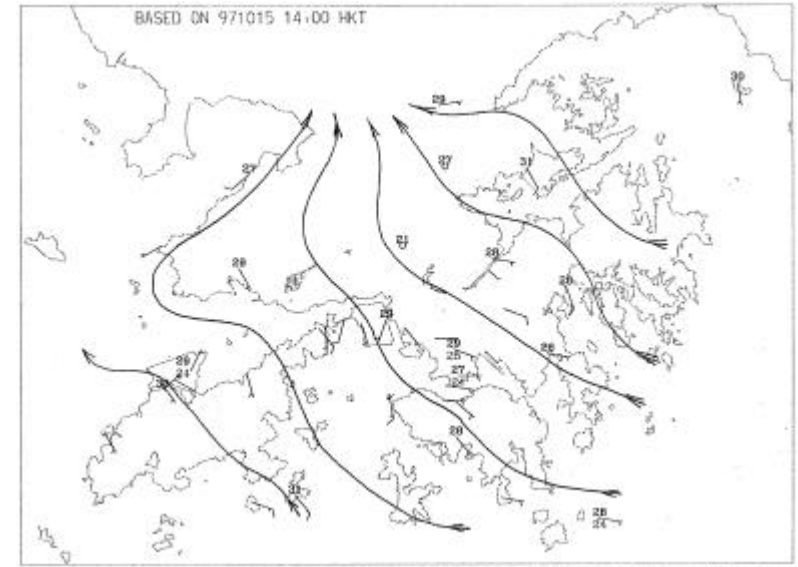

(d)

Figure 20 Wind flow over Hong Kong on 15 October 1997 at (a) 9 a.m., (b) 10 a.m., (c) 11 a.m., (d) 2 p.m..

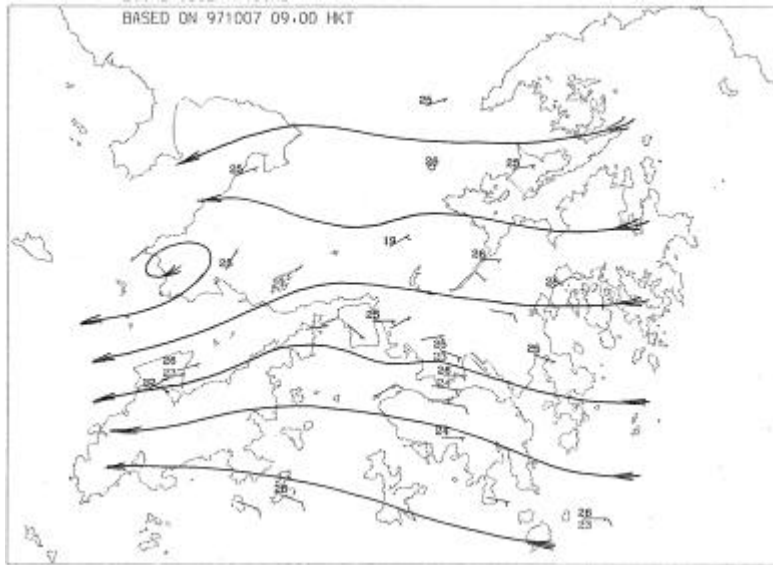

(a)

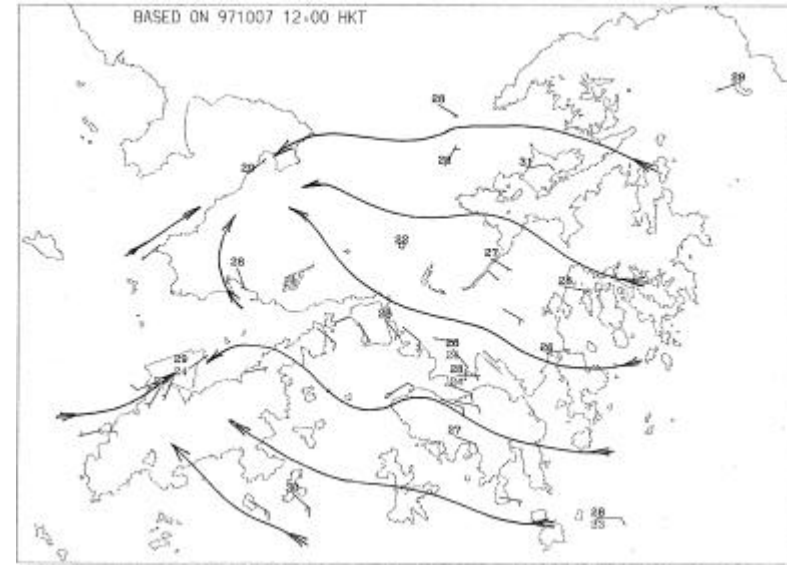

(b)

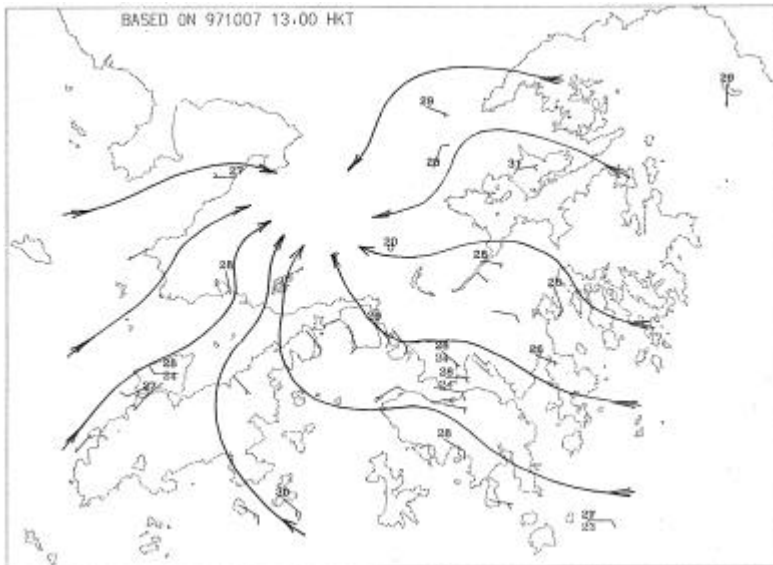

(c)

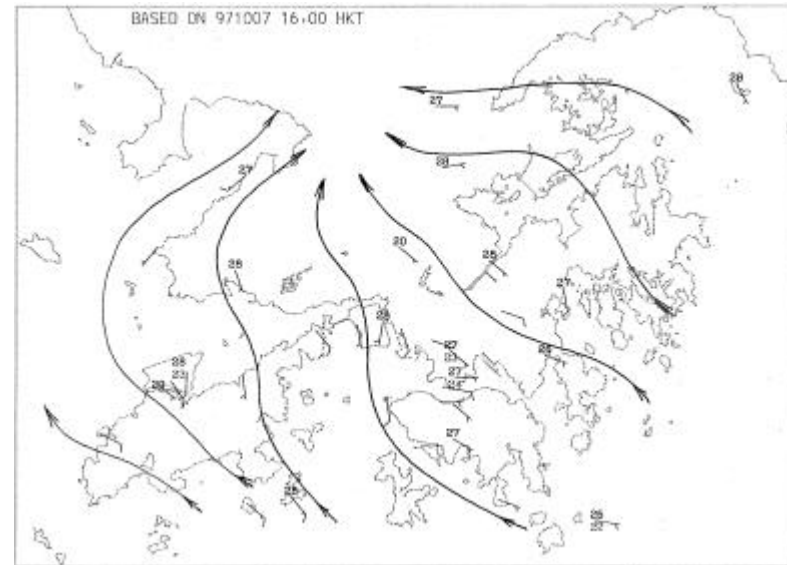

(d)

Figure 21 Wind flow over Hong Kong on 7 October 1997 at (a) 9 a.m., (b) noon, (c) 1 p.m., (d) 4 p.m..

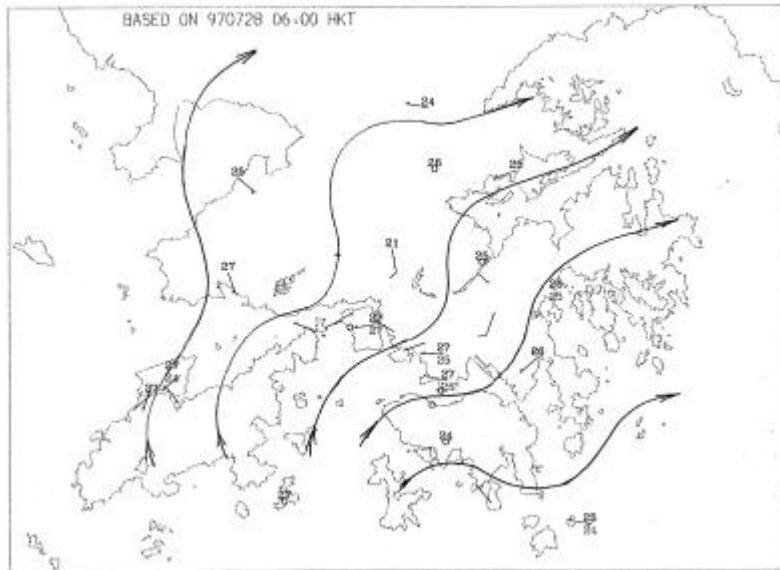

(a)

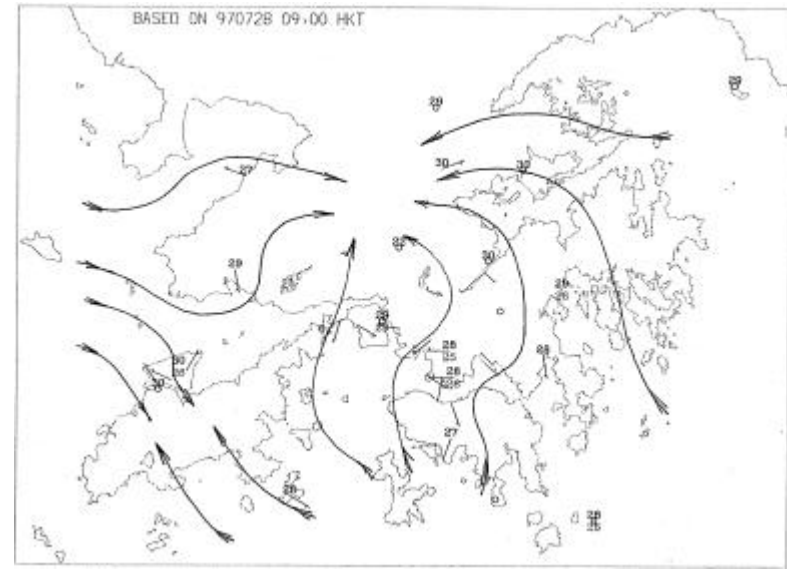

(b)

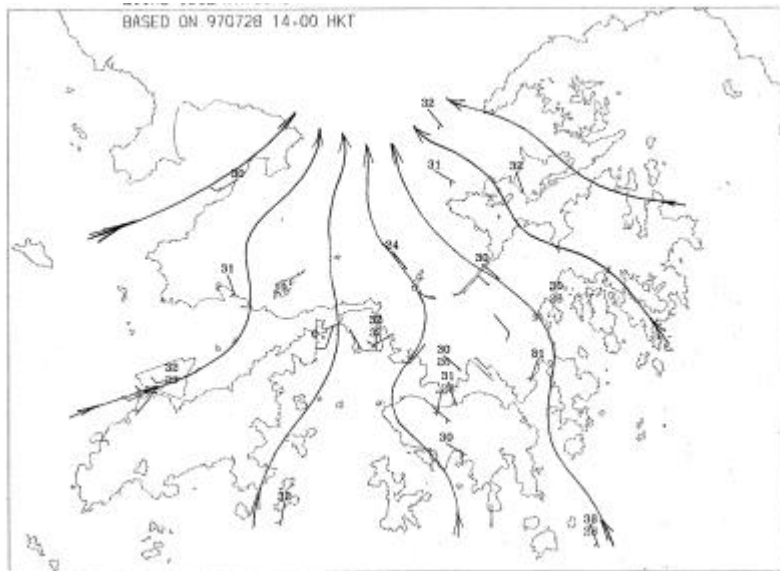

(c)

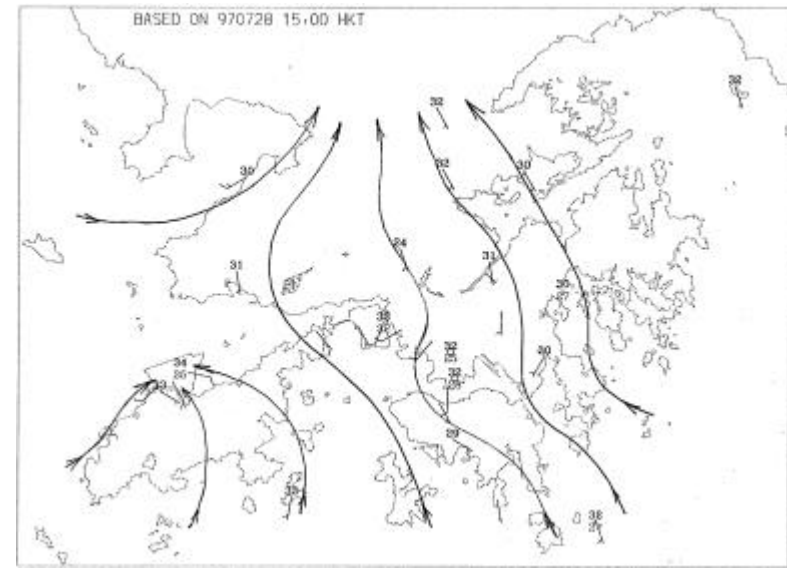

(d)

Figure 22 Wind flow over Hong Kong on 28 July 1997 at (a) 6 a.m., (b) 9 a.m., (c) 2 p.m., (d) 3 p.m..

ACKNOWLEDGMENT

The authors would like to thank Mr. K.P Wong and his colleagues for their assistance in preparing data for this study.

REFERENCES

- Atkinson, B.W., "Meso-scale Atmospheric Circulations " , Academic Press, 1981.
- Hsu, S.A., "Coastal Meteorology", Academic Press, 1988.
- Simpson, J.E., "Sea Breeze and Local Winds", Cambridge University Press, 1994